

Name: \_\_\_\_\_

Date: \_\_\_\_\_

# Lakelands Park Middle School

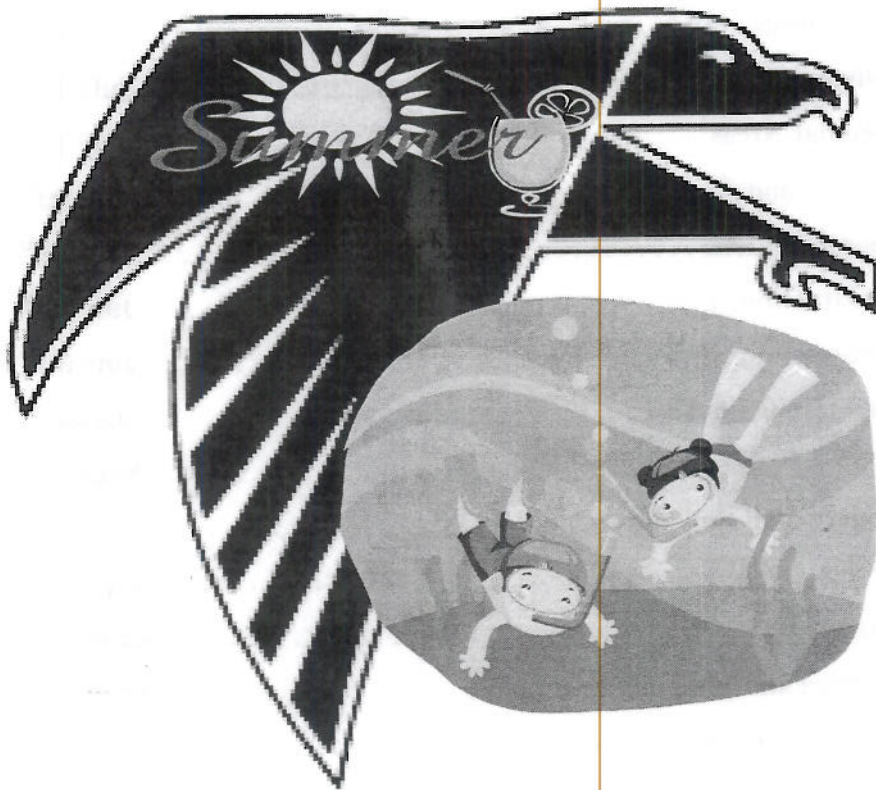

# Honors Geometry Summer Packet

# Geometry Summer Mathematics Packet

## Table of Contents

Page	Objective	Suggested Completion Date
1	Squares, Square Roots, and the Laws of Exponents . . . . .	June 22 <sup>nd</sup>
2	Simplifying Radicals . . . . .	June 25 <sup>th</sup>
3	Solving Equations I . . . . .	June 29 <sup>th</sup>
4	Solving Equations II . . . . .	July 6 <sup>th</sup>
5	Inequalities . . . . .	July 9 <sup>th</sup>
6	Pythagorean Theorem . . . . .	July 13 <sup>th</sup>
7	Irregular Areas . . . . .	July 16 <sup>th</sup>
8	Volume and Surface Area . . . . .	July 20 <sup>th</sup>
9	Venn Diagrams . . . . .	July 23 <sup>rd</sup>
10	Constructions I . . . . .	July 27 <sup>th</sup>
11	Constructions II . . . . .	July 30 <sup>th</sup>
12	Angle Relationships . . . . .	August 3 <sup>rd</sup>
13	Solving Problems involving Shapes . . . . .	August 6 <sup>th</sup>
14	Properties of Polygons . . . . .	August 9 <sup>th</sup>
15	Circles . . . . .	August 12 <sup>th</sup>
16	Similarity . . . . .	August 15 <sup>th</sup>
17	Distance and Midpoint Formulas . . . . .	August 18 <sup>th</sup>
18	Factoring Quadratic Equations . . . . .	August 21 <sup>st</sup>
19	Solving Systems of Equations . . . . .	August 24 <sup>th</sup>
20	Probability . . . . .	August 27 <sup>st</sup>

## Summer Mathematics Packet

### Squares, Square Roots, and the Laws of Exponents

Hints/Guide:

Exponents are a way to represent repeated multiplication, so that  $3^4$  means 3 multiplied four times, or  $3 \cdot 3 \cdot 3 \cdot 3$ , which equals 81. In this example, 3 is the base and 4 is the power.

Roots are the base numbers that correspond to a given power, so the square (referring to the power of 2) root of 81 is 9 because  $9 \cdot 9 = 81$  and the fourth root of 81 is 3 because  $3 \cdot 3 \cdot 3 \cdot 3$  is 81.

$\sqrt[n]{x}$ , where n is the root index and x is the radicand

There are certain rules when dealing with exponents that we can use to simplify problems. They are:

Adding powers  $a^m a^n = a^{m+n}$

Multiplying powers  $(a^m)^n = a^{mn}$

Subtracting powers  $\frac{a^m}{a^n} = a^{m-n}$

Negative powers  $a^{-n} = \frac{1}{a^n}$

To the zero power  $a^0 = 1$

Exercises: Evaluate:

1.  $(8 - 4)^2 =$

2.  $(4 - 2)^2 (5 - 8)^3 =$

3.  $5(8 - 3)^2 =$

4.  $\sqrt{25 - 16} =$

5.  $\sqrt{5(9 \cdot 125)} =$

6.  $\sqrt{(8 - 4)(1 + 3)} =$

Simplify the following problems using exponents (Do not multiply out):

7.  $5^2 5^4 =$

8.  $(12^4)^3 =$

9.  $5^9 \div 5^4 =$

10.  $10^3 \div 10^{-5} =$

11.  $7^{-3} =$

12.  $3^{-4} =$

13.  $(3^3 \cdot 3^2)^3 =$

14.  $5^3 \cdot 5^4 \div 5^7 =$

## Summer Mathematics Packet

### Simplifying Radicals

Hints/Guide:

To simplify radicals, first factor the radicand as much as possible, then "pull out" square terms using the following rules:

$$\sqrt{a^2} = a$$

$$\sqrt{ab} = \sqrt{a}\sqrt{b}$$

$$\sqrt{\frac{a}{b}} = \frac{\sqrt{a}}{\sqrt{b}} \text{ as long as } b \neq 0$$

A radical is in simplest form when:

- there is no integer under the radical sign with a perfect square factor,
- there are no fractions under the radical sign, and
- there are no radicals in the denominator.

Exercises: Simplify each expression.

1.  $\sqrt{\frac{15}{81}} =$

2.  $\sqrt{24} + 5\sqrt{6} =$

3.  $\sqrt{75} + \sqrt{243} =$

4.  $4 + 2\sqrt{10} =$

5.  $\sqrt{28} + \sqrt{7} =$

6.  $\sqrt{\frac{27}{49}} =$

7.  $5\sqrt{3} - \sqrt{75} =$

8.  $4\sqrt{3} \cdot \sqrt{18} =$

9.  $\sqrt{128} - \sqrt{8} =$

10.  $(5\sqrt{3})^2 =$

11.  $\sqrt{128} + \sqrt{50} =$

12.  $\sqrt{75} \cdot \sqrt{27} =$

13. Nina says that  $16 + 4\sqrt{2}$  cannot be simplified. George says that it can be simplified to  $20\sqrt{2}$ . Who is correct? Explain how you know.

## Summer Mathematics Packet

### Solving Equations I

Hints/Guide:

The key in equation solving is to isolate the variable, to get the letter by itself. In two-step equations, we must undo addition and subtraction first, then multiplication and division. Remember the golden rule of equation solving: If we do something to one side of the equation, we must do the exact same thing to the other side. Examples:

1.  $4x - 6 = -14$

$$\begin{array}{r} +6 \quad +6 \\ \hline 4x \quad = -8 \end{array}$$

$$\begin{array}{r} 4 \quad 4 \\ \hline \end{array}$$

$$x = -2$$

Solve:  $4(-2) - 6 = -14$

$$-8 - 6 = -14$$

$$-14 = -14$$

2.  $\frac{x}{-6} - 4 = -8$

$$\begin{array}{r} +4 \quad +4 \\ \hline \end{array}$$

$$-6 \cdot \frac{x}{-6} = -4 \cdot -6$$

$$x = 24$$

Solve:  $(24/-6) - 4 = -8$

$$-4 - 4 = -8$$

$$-8 = -8$$

When solving equations that include basic mathematical operations, we must simplify the mathematics first, then solve the equations. For example:

$$5(4 - 3) + 7x = 4(9 - 6)$$

$$5(1) + 7x = 4(3)$$

$$\begin{array}{r} 5 \quad + 7x = 12 \\ -5 \quad \quad -5 \end{array}$$

$$\frac{7x}{7} = \frac{7}{7}$$

$$x = 1$$

Check:  $5(4 - 3) + 7(1) = 4(9 - 6)$

$$\begin{array}{r} 5 \quad + \quad 7 = 4(3) \\ 12 \quad = 12 \end{array}$$

Exercises: Solve the following equations using the rules listed on the previous pages:

SHOW ALL WORK. Use a separate sheet of paper (if necessary) and staple to this page.

1.  $-4t + 3t - 8 = 24$

2.  $\frac{m}{-5} + 6 = 4$

3.  $-4r + 5 - 6r = -32$

4.  $\frac{x}{-3} + (-7) = 6$

5.  $6g + (-3) = -12$

6.  $\frac{y}{-2} + (-4) = 8$

7.  $9 - 5(4 - 3) = -16 + \frac{x}{3}$

8.  $6t - 14 - 3t = 8(7 - (-2))$

9.  $7(6 - (-8)) = \frac{t}{-4} + 2$

10.  $7(3 - 6) = 6(4 + t)$

11.  $4r + 5r - 8r = 13 + 6$

12.  $3(7 + x) = 5(7 - (-4))$

13. Explain in words how to solve a two step equation, similar to any of the equations in problems 2 through 6 above.

**Solving Equations II**

Hints/Guide:

As we know, the key in equation solving is to isolate the variable. In equations with variables on each side of the equation, we must combine the variables first by adding or subtracting the amount of one variable on each side of the equation to have a variable term on one side of the equation. Then, we must undo the addition and subtraction, then multiplication and division. Remember the golden rule of equation solving. Examples:

$$\begin{array}{r} 8x - 6 = 4x + 5 \\ -4x \quad -4x \\ \hline 4x - 6 = 5 \\ +6 \quad +6 \\ \hline 4x = 11 \\ \frac{4x}{4} = \frac{11}{4} \end{array}$$

$$x = 2\frac{3}{4}$$

$$\begin{array}{r} 5 - 6t = 24 + 4t \\ +6t \quad +6t \\ \hline 5 = 24 + 10t \\ -24 \quad -24 \\ \hline -19 = 10t \\ \frac{-19}{10} = \frac{10t}{10} \end{array}$$

$$-1\frac{9}{10} = t$$

Exercises: Solve the following problems:

No Calculators!

SHOW ALL WORK. Use a separate sheet of paper (if necessary) and staple to this page.

1.  $4r - 7 = 6r + 16 - 3r$       2.  $13 + 3t = 5t - 9$       3.  $-3x + 5 = 3x - 3$

4.  $6y + 5 = 6y - 15$       5.  $5x - 8 = 6 - 7x + 2x$       6.  $7p - 8 = -6p + 8$

7. **Rowboat Rentals:** \$5.00 per hour plus a \$100.00 deposit. *Deposit will be refunded if the boat is returned undamaged.*

Which equation represents the total cost for renting and returning a row-boat undamaged? Let  $c$  be the total cost in dollars and  $t$  be the time in hours.

- a.  $c = 5t + 100$       b.  $c = 500t$   
 c.  $c = 100t + 5$       d.  $c = 5t$

8. Ted wants to buy a \$400.00 bike. He has two options for payment.

Option One: Ted can borrow the \$400.00 from his father and repay him \$40.00 a month for a year.

Option Two: The bike shop will finance the bike for one year at a 15% annual interest rate. The formula for the total amount paid ( $a$ ) is:

$$a = p + prt, \text{ where } p \text{ is the amount borrowed, } r \text{ is the rate of interest, and } t \text{ is the time in years.}$$

Which option would cost Ted the least amount of money?

Explain how you determined your answer. Use words, symbols, or both in your explanation.

## Summer Mathematics Packet

### Inequalities

#### Hints/Guide:

In solving inequalities, the solution process is very similar to solving equalities. The goal is still to isolate the variable, to get the letter by itself. However, the one difference between equations and inequalities is that when solving inequalities, when we multiply or divide by a negative number, we must change the direction of the inequality. Also, since an inequality has many solutions, we can represent the solution of an inequality by a set of numbers or by the numbers on a number line.

Inequality - a statement containing one of the following symbols:

$<$  is less than                       $>$  is greater than                       $\leq$  is less than or equal to  
 $\geq$  is greater than or equal to                       $\neq$  is not equal to

#### Examples:

1. Integers between -4 and 4.

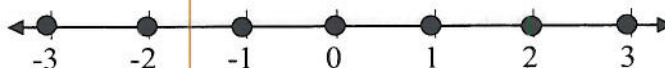

2. All numbers between -4 and 4.



3. The positive numbers.



So, to solve the inequality  $-4x < -8$  becomes  $\frac{-4x}{-4} < \frac{-8}{-4}$

and therefore  $x > 2$  is the solution (this is because whenever we multiply or divide an inequality by a negative number, the direction of the inequality must change) and can be represented as:



Exercises: Solve the following problems:

No Calculators!

1.  $4x > 9$



2.  $-5t \geq -15$



3.  $\frac{x}{2} \geq 3$



4.  $\frac{x}{-4} > 2$



Summer Mathematics Packet

Pythagorean Theorem

Hints/Guide:

The Pythagorean Theorem states that in a right triangle, and only in a right triangle, the length of the longest side (the side opposite the right angle and called the hypotenuse, or  $c$  in the formula) squared is equal to the sum of the squares of the other two sides (the sides that meet to form the right angle called legs, or  $a$  and  $b$  in the formula). The formula is  $a^2 + b^2 = c^2$ .

Find the missing side.

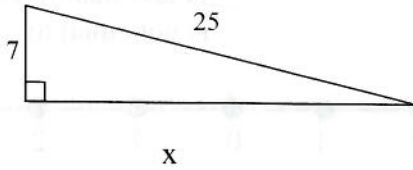

$$\begin{aligned} a^2 + b^2 &= c^2 \\ 7^2 + x^2 &= 25^2 \\ 49 + x^2 &= 625 \\ -49 \quad -49 & \\ x^2 &= 576 \\ \sqrt{x^2} &= \sqrt{576} \\ x &= 24 \end{aligned}$$

Exercises: Solve for the variable:

SHOW ALL WORK. Use a separate sheet of paper (if necessary) and staple to this page.

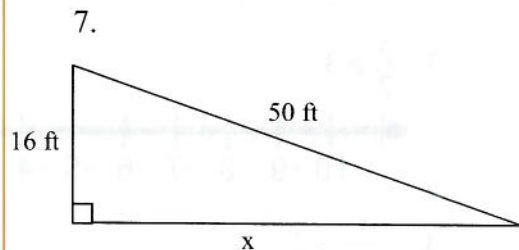
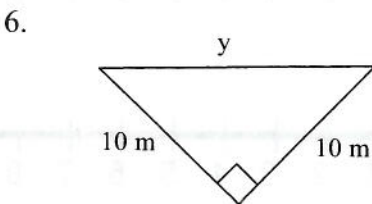
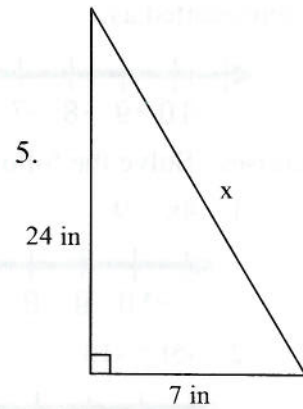
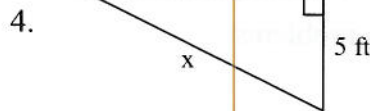
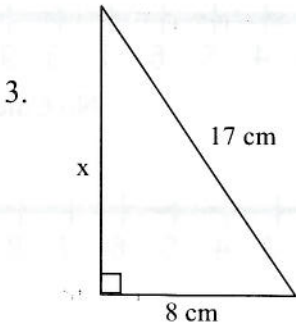
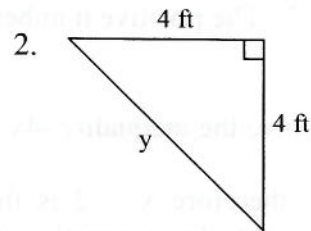
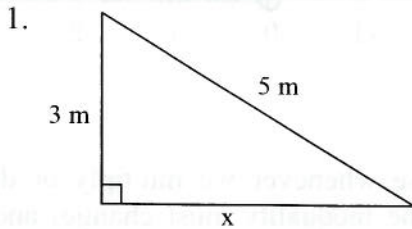



Summer Mathematics Packet

Irregular Area

Hints/Guide:

To solve problems involving irregular area, use either an additive or a subtractive method. In an additive area problem, break the object down into known shapes and then add the areas together. In a subtractive area problem, subtract the area of known shapes from a larger whole.

Exercises:

1. The baking sheet shown holds 12 cookies. Each cookie has a diameter of 3 inches.

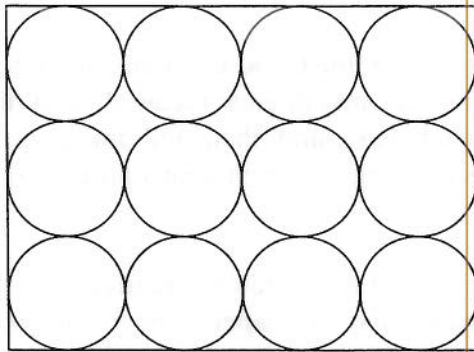

What is the area of the unused part of the baking sheet? Round your answer to the nearest square inch.

2. Find the area of the shaded regions.

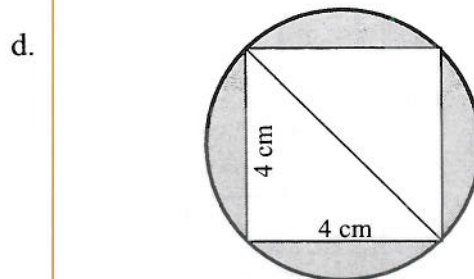
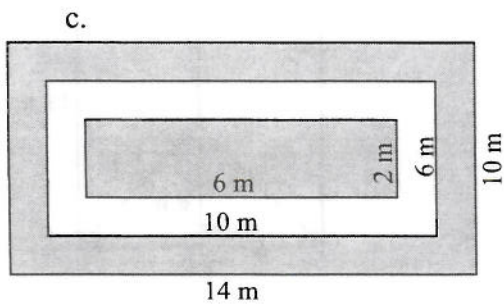
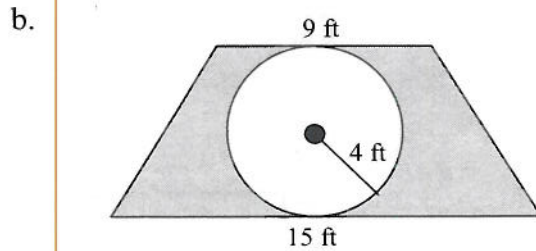
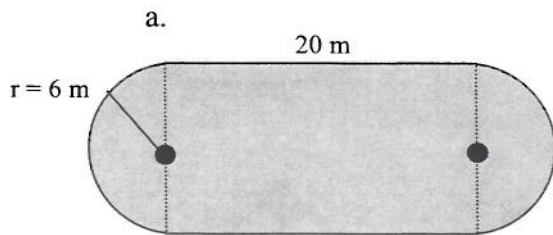

**Volume and Surface Area**

Hints/Guide:

To find the volume of prisms (a solid figure whose ends are parallel and the same size and shape and whose sides are parallelograms) and cylinders, we multiply the area of the base times the height of the figure. The formulas we need to know are:

The area of a circle is  $A = \pi r^2$

The area of a rectangle is  $A = bh$

The area of a triangle is  $A = \frac{1}{2}bh$

The volume of a prism is  $V = \text{Base Area} \cdot h$

So, the volume of a rectangular prism can be determined if we can find the area of the base and the perpendicular height of the figure.

To determine the surface area of an object, we must find the areas of each surface and add them together. For a rectangular prism, we find the area of each rectangle and then add them together. For a cylinder, we find the area of each base and then add the area of the rectangle (the circumference of the circular base times the height) which wraps around to create the sides of the cylinder.

Exercises: Find the volume and surface area of the following figures: Note: Use  $\pi = 3.14$   
 SHOW ALL WORK. Use a separate sheet of paper (if necessary) and staple to this page.

1.

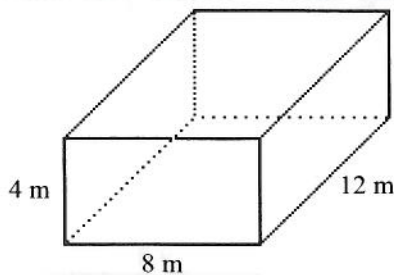

2.

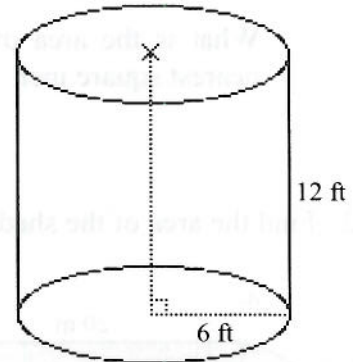

3.

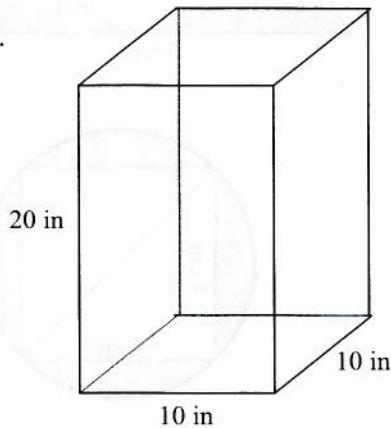

4.

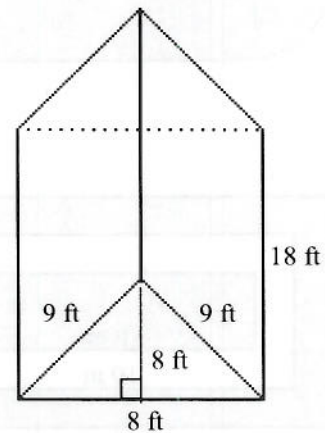

## Summer Mathematics Packet

### Venn Diagrams

Hints/Guide:

Venn Diagrams can be used to aid on solving problems involving sets. Venn Diagrams can be used to show the relationships between sets, such as between odd numbers less than 20 and prime numbers less than 20:

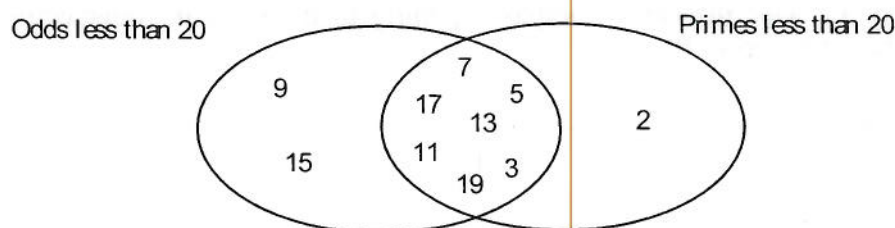

Notice how, in the example, numbers that are in both sets are listed in the intersection of the two circles. By using this in solving problems, we can eliminate the problem of counting an item or person twice that may appear in more than one set.

Exercises:

1. On one particular day, 49 people purchased drinks from a vending machine. If 27 people purchased Mighty Grape Soda and 30 purchased Tree Root Beer, how many people purchased both?
2. While watching the Staff-Student Basketball Game, 30 fans cheered for the Staff, 50 cheered for the Students, and 17 cheered for both. If there were 65 fans watching the game, how many people cheered for neither?
3. In a recent sixth grade survey, out of 324 students, the following information was collected regarding condiments for hot dogs. The results were: 144 liked mustard, 241 liked ketchup, 97 liked pickle relish, 49 liked ketchup and pickle relish but not mustard, 14 liked mustard and pickle relish but not ketchup, 81 like mustard and ketchup but not pickle relish, and 32 like only mustard.
  - a. How many do not like any of these three condiments on their hot dog?
  - b. How many like exactly one of these three on their hot dog?
  - c. How many like exactly two of these three on their hot dog?

## Summer Mathematics Packet

### Constructions I

Copy a line segment (use only a compass and a straight edge - no measuring)

Draw a segment longer than the original segment (AB). Mark a point (A') on this drawn segment. Place the compass tip on point A. Draw an arc through B. Place the compass point on A'. Use the same compass opening to draw an arc intersecting the segment. Label the intersection B'.



Copy an angle

Draw a ray and label it ray B'C'. Place the metal tip on B. Strike an arc intersecting rays BA and BC. Without changing the compass setting, put the metal tip on B', and strike an arc intersecting ray B'C'. Label the points of intersection P and Q on the original, and Q' on the copy. Place the compass tip on Q and use the compass to measure the distance to P. Without changing the compass setting, place the metal tip on Q' and make an arc intersecting with the first arc through Q'. Label the intersection of the arcs P'. Draw ray B'P'.

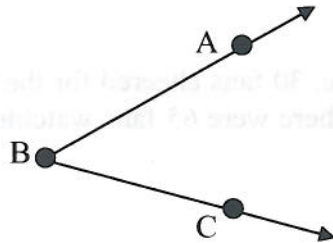

Bisect a line

With the compass setting greater than one-half the distance from A to B, place the metal tip on A and strike arcs above and below the segment. Without changing the compass setting, place the metal tip on B and do the same thing. Draw PQ. It will intersect AB at its midpoint forming 90 degree angles.



Summer Mathematics Packet

Constructions II

Bisect an angle

Place the metal tip of the compass on vertex B and strike an arc that intersects both sides of the angle. Label the intersections P and Q. Place the metal tip on P and with the compass setting greater than one-half the distance from P to Q, strike an arc. Without changing the setting, place the metal tip on Q and strike an arc, intersecting the one drawn from P. Label the intersection of the arcs D. Draw BD. It is the bisector.

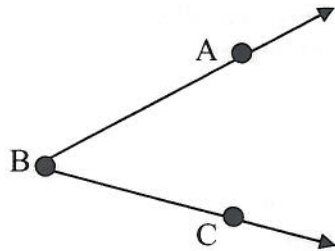

Construct a perpendicular through a point off the line

Place metal tip of the compass on A and with the compass setting greater than the distance from A to the line, strike an arc with intersects the line twice (you might need to extend the line). Label the intersections R and S. Place the metal tip first on S, and without changing the compass setting, strike an arc on the other side of the line. Then do the same from R. Label the intersection of these arcs B. Draw AB, and it is the perpendicular bisector and PQ.

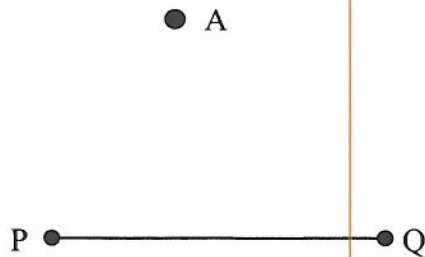

### Angle Relationships

Hints/Guide:

To solve these problems, you will need to know some basic terms:

Two angles that sum to 180 degrees are called supplementary.

Two angles that sum to 90 degrees are called complementary.

Two angles that have the same angular measure are called congruent.

When a line (called a transversal) intersects a pair of parallel lines, it forms eight angles.

Angles 1 and 5 are corresponding.

Angles 1 and 8 are alternate exterior.

Angles 3 and 6 are alternate interior.

Angles 1 and 7 are same side exterior.

Angles 3 and 5 are same side interior.

Same side interior and same side exterior are supplementary angles.

Alternate interior and alternate exterior are congruent angles.

Corresponding angles are congruent angles.

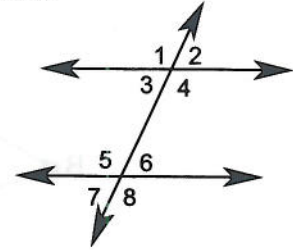

Exercises:

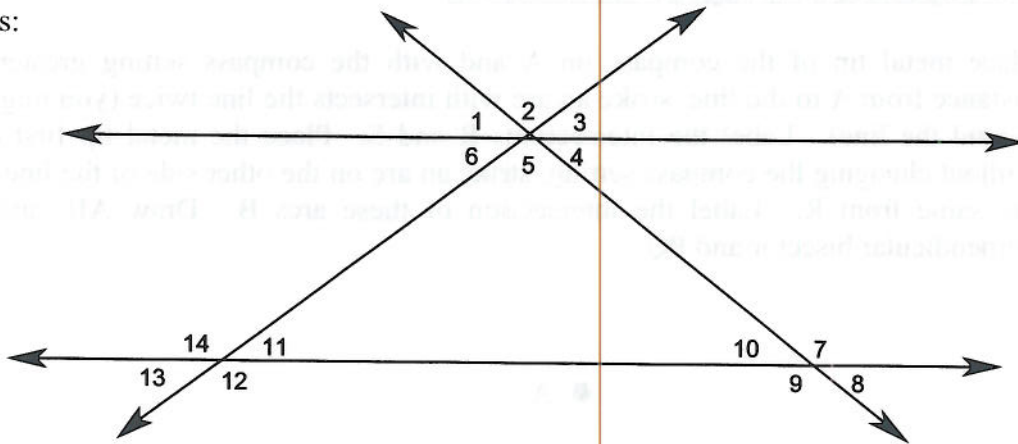

If the measure of Angle 10 is  $54^\circ$  and Angle 11 is  $46^\circ$ , what is the measure of:

- |                      |                      |
|----------------------|----------------------|
| 1. Angle 1 = _____   | 2. Angle 2 = _____   |
| 3. Angle 3 = _____   | 4. Angle 4 = _____   |
| 5. Angle 5 = _____   | 6. Angle 6 = _____   |
| 7. Angle 7 = _____   | 8. Angle 8 = _____   |
| 9. Angle 9 = _____   | 10. Angle 12 = _____ |
| 11. Angle 13 = _____ | 12. Angle 14 = _____ |

Summer Mathematics Packet

Solving Problems Involving Shapes

Hints/Guide:

To solve these problems, you will need to recall many facts, including:

There are 180 degrees in every triangle.

Isosceles triangles have two equal sides and two equal angles.

Equilateral triangles have three equal sides and three equal angles.

Quadrilaterals have an interior angle sum of 360 degrees.

Regular polygons have all sides equal and all angles equal.

The sum of the angles of a regular polygon can be found using  $(n - 2) \cdot 180$ .

The number of diagonals of any polygon can be found using  $n(n - 3) \div 2$ .

Concave polygon has one or more diagonals with points outside the polygon.

Convex polygon has all interior angles less than 180 degrees.

Exercises:

1. Triangle ABC is isosceles with the measure of  $\angle A = 30^\circ$

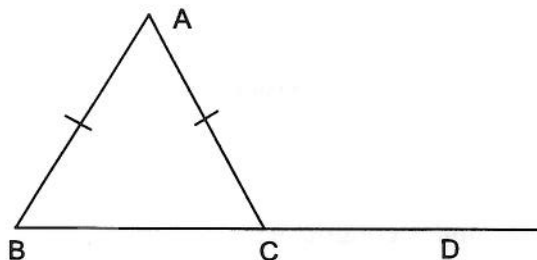

What is the measure of  $\angle ACD$ ?

2. How many degrees in each angle of a regular hexagon? a regular octagon?

3. How many diagonals in a pentagon? an octagon? a decagon?

4. Solve for the missing angle (not drawn to scale)

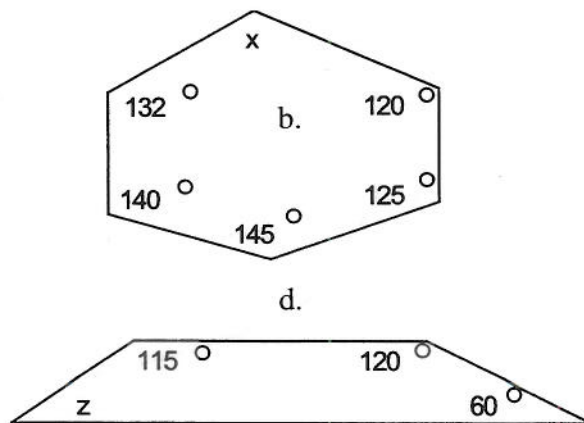
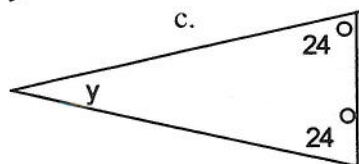
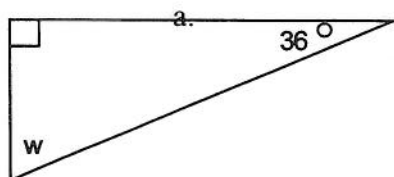

Properties of Polygons

Hints/Guide:

To answer these questions, you will need to find the definitions of these terms:

- |               |           |           |
|---------------|-----------|-----------|
| Quadrilateral | Rectangle | Square    |
| Parallelogram | Rhombus   | Trapezoid |

Exercises:

1. What is a four sided figure with two pairs of parallel sides?
2. What is a four sided figure with exactly one pair of parallel sides?
3. What is a four sided figure with all sides congruent length?
4. What is a four sided figure with all angles congruent?
5. What is a four sided figure with all angles and sides congruent?
6. What is a four sided figure?
7. What is a four sided figure with opposite angles congruent?
8. Fill in each section of the Venn Diagram below with the 6 terms above.

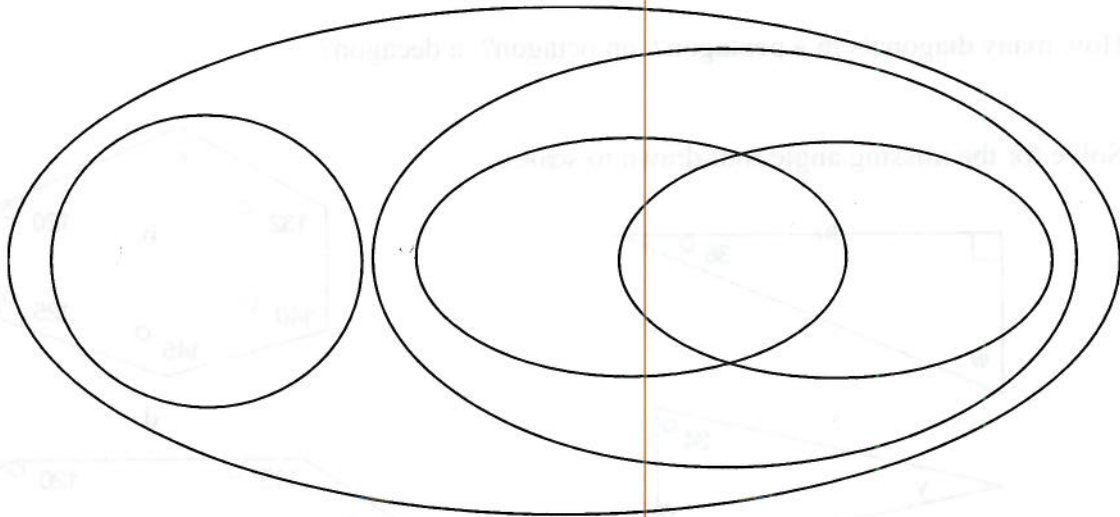



Summer Mathematics Packet

Circles

Hints/Guide:

There is some basic terminology that is needed for geometry. You need to know:

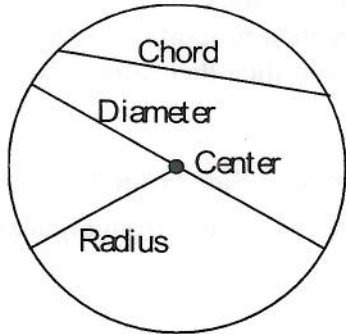

$$\text{Circumference} = 2\pi r = \pi d$$

$$\text{Area} = \pi r^2$$

AB is a minor arc (less than  $180^\circ$ )  
ACB is a major arc (greater than  $180^\circ$ )

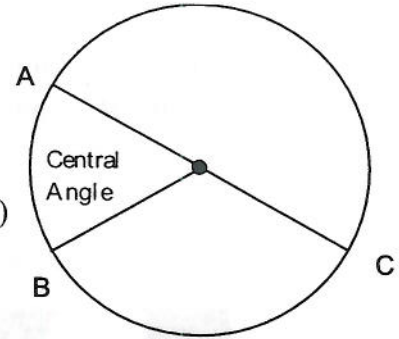

Exercises: Find the circumference and area of each circle. Use  $\pi = 3.14$

1.

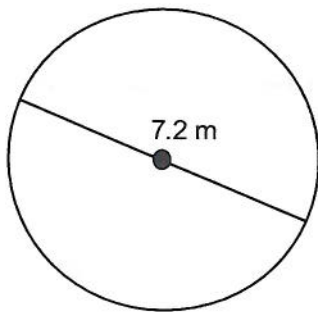

2.

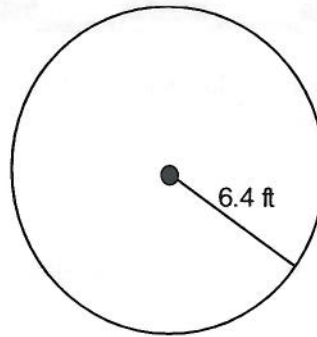

3.

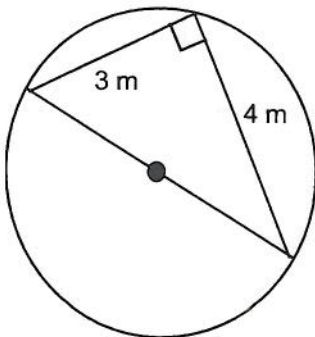

4.

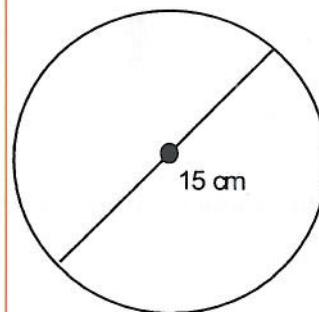

Summer Mathematics Packet

Similarity

Hints/Guide:

Similarity in geometry, unlike the common usage of the term, does not mean the same, but rather means that figures have the same shape but may be different sizes (think of a photograph negative and a photo enlargement). To solve similarity problems, create a proportion with either the corresponding sides in one ratio compared to corresponding sides in the other ratio, or create a proportion organized according to the figure:

$$\frac{\text{Side 1 from figure A}}{\text{Side 1 from Figure B}} = \frac{\text{Side 2 from Figure A}}{\text{Side 2 from Figure B}} \quad \text{or} \quad \frac{\text{Side 1 from Figure A}}{\text{Side 2 from Figure A}} = \frac{\text{Side 1 from Figure B}}{\text{Side 2 from Figure B}}$$

Exercises:

1. A 5-inch by 7-inch picture is placed into a rectangular frame. The frame is 2 inches wide.

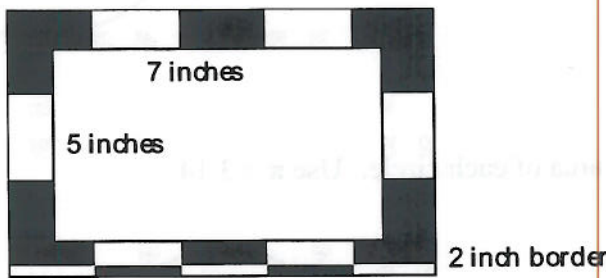

Is the rectangular border of the picture similar to the outer border of the frame? Justify your answer.

2. John wanted to measure the height (h) of the room shown below. John is 6 feet tall.

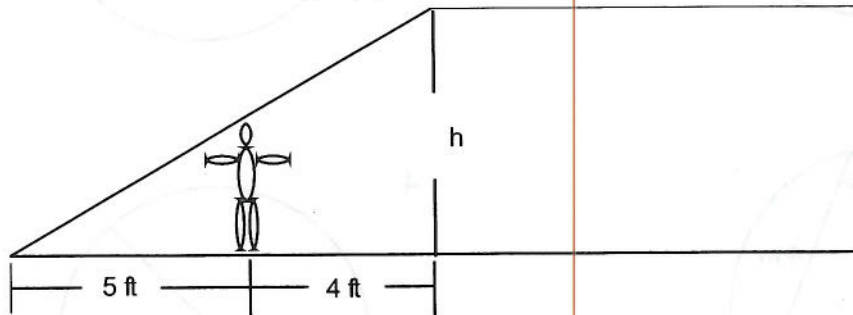

What is the height (h) of the room. Round your answer to the nearest foot.

Summer Mathematics Packet

Distance and Midpoint Formulas

Hints/Guide:

To find the distance between two points, we use the distance formula, which is:

$$Distance = \sqrt{(x_2 - x_1)^2 + (y_2 - y_1)^2}$$

To find the midpoint of two points, we use the midpoint formula, which is:

$$Midpoint = \left( \frac{x_1 + x_2}{2}, \frac{y_1 + y_2}{2} \right)$$

Exercises:

1. Find the distance between points

- a. A and B
- b. C and E
- c. D and E
- d. A and E

2. Find the midpoint of segment

- a. AB
- b. CE
- c. DE
- d. AE

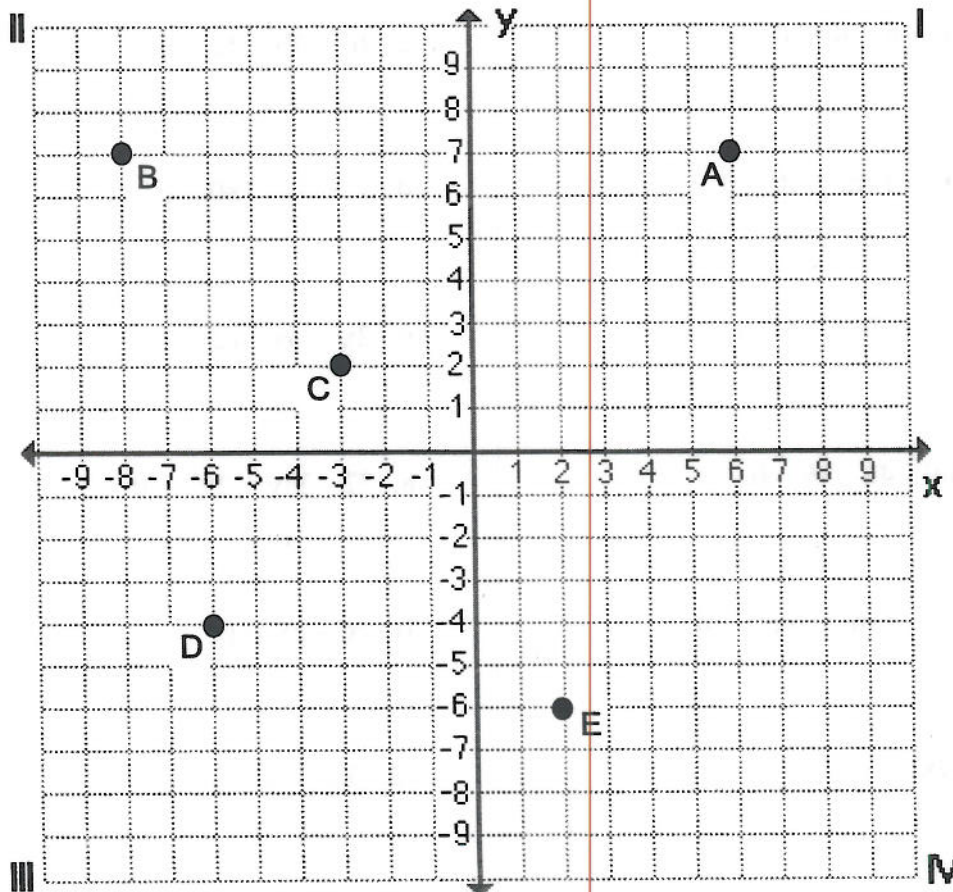

**Factoring Quadratic Equations**

Hints/Guide:

Factoring a polynomial can make a problem easier to solve or allow one to easily find the roots of an equation. Factoring can be thought of as the opposite of distribution because terms are expanded, usually from a trinomial (three term) equation to an equation which is the product of two binomial (two) terms.

Examples:  $x^2 + 5x + 6 = (x + 2)(x + 3)$   
 $2x^2 - 3x - 2 = (2x + 1)(x - 2)$

If these equations are set to zero, then we can solve for the roots of the equation by setting each binomial term to zero.

Example:  $2x^2 - 3x - 2 = 0$                        $(2x + 1)(x - 2) = 0$   
 which means that  $2x + 1 = 0$  or  $x - 2 = 0$  because if the product is zero,  
 then one of the factors must be zero.  
 therefore,  $x = -0.5$  or  $x = 2$ .

Exercises: Find the roots of each equation.

1.  $a^2 + a - 30 = 0$

2.  $b^2 + 7b + 12 = 0$

3.  $m^2 - 14m + 40 = 0$

4.  $s^2 + 3s - 180 = 0$

5.  $7a^2 + 22a + 3 = 0$

6.  $2x^2 - 5x - 12 = 0$

7.  $4n^2 - 4n - 35 = 0$

8.  $72 - 26y + 2y^2 = 0$

9.  $10 + 19m + 6m^2 = 0$

10.  $x^2 - 2x = 15$

11.  $2x^2 + x = 3$

12.  $3x^2 - 4x = 4$

## Summer Mathematics Packet

### Solving Systems of Equations

#### Hints/Guide:

A system of equations occurs when a situation involves multiple components that can individually be described using equations. Where these equations intersect, their  $x$  and  $y$  values are the same. Graphically, this appears as an intersection of lines. Algebraically, the  $x$  and  $y$  values that solve simultaneous equations are the same. The three primary methods of solving systems of equations are graphically, by substitution, and by linear combination.

Exercises: Solve each system of equations using any method.

1.  $3x - 4y = 3$   
 $6x + 8y = 54$

2.  $9 = 5x + 2y$   
 $-31 = 3x - 4y$

3.  $2x - 7y = 19$   
 $-6x - 21y = -15$

4.  $4x - 11y = -9$   
 $-6x + 22y = 8$

5. Hanz and Mario went to a sale at a music store where all CDs were one price and all cassettes were another price. Hanz bought 2 CDs and 2 cassettes for \$40.00, while Mario bought 1 CD and 4 cassettes for \$44.00.

The equations below represent these purchases, where  $x$  is the cost of a CD and  $y$  is the cost of a cassette.

Hanz  $2x + 2y = 40$

Mario  $x + 4y = 44$

What are the costs of a single CD and a single cassette? Solve the system of equations by either constructing a graph on a sheet of graph paper or by using an algebraic process. Explain how you determined the costs. Use words, symbols, or both in your explanation.

6. An exam will have 20 questions and be worth a total of 100 points. There will be a true/false section where the questions are worth 3 points each and a short essay section where the questions will be worth 11 points each. How many essay questions will there be on the test?

## Summer Mathematics Packet

### Probability

Hints/Guide:

Probability is the number of times something will happen compared to the total number of possibilities. Probability can be expressed as a fraction, a ratio, or a percent, and always is between 0 and 1.

Exercises:

1. All 15 students in Joe's English class must give an oral report. The teacher randomly selects 1 student each day to present his or her report. If by the end of the third day Joe has not been selected, what is the probability that the teacher will select Joe on the fourth day?
2. The table below shows the results of a survey given to 100 randomly selected seniors at Willis High School concerning their plans after graduation.

Activity	Number of Students
Attend 2-year college	36
Attend 4-year college	21
Attend technical school	17
Join the military	5
Work full time	14
Other	7

Use this data to predict the probability that a senior at Willis High School plans to join the military after graduation.

3. If a computer randomly chooses a letter in the word "probability," what is the probability it will select a
  - a. p ?
  - b. r ?
  - c. b ?
  - d. a ?
  - e. i ?
  - f. y ?
4. If a card is selected at randomly from a deck of 52 standard playing cards, what is the probability of selecting
  - a. a red queen?
  - b. a black card?
  - c. the jack of hearts?
  - d. a prime number?